



MINMAX[®]
POWER FOR A BETTER FUTURE

2020

**RAILWAY CERTIFIED
POWER SOLUTION
GUIDE**

► RAILWAY CERTIFIED POWER SOLUTIONS ENGINEERED BY MINMAX

The MINMAX Railway Certified DC-DC Converter family with powers ranging from 3 to 150 W are designed to meet stringent requirements and harsh environmental testing and are specifically designed to be the primary insulation barriers for railway DC power architectures. These railway certified DC-DC converters are available for DC battery bus voltages of 24, 36, 48, 72, 96, and 110 VDC, and for tight regulation for output voltages of 5, 12, 15, 24, 54, ± 12 , and ± 15 VDC. In accordance with EN 50155:2017 certification requirements, these railway certified DC-DC converters conform to the railway DC input-voltage range and transient/variation requirements; the voltage isolation/withstand test vibration and shock/bump test requirements in EN 61373; the cooling, dry, and damp heat test requirements in IEC/EN 60068-2-1, 2, and 30; and the EMC railway standards in EN 50121-3-2.

An advanced circuit topology provides a very high efficiency up to 93%, which allows a base plate temperature up to 105 ° C and very high I/O isolation up to 3000 VAC with reinforced insulation. Further features include overload, overvoltage, and short-circuit protection; remote ON/OFF; output trim; and output sense. For fire protection testing, these converters meet the EN 45545-2 standard to ensure system safety.

THE INTRODUCTION OF RAILWAY CERTIFICATION EN 50155:2017

Fundamental Introduction	02
Input Voltage Specification Test for EN 50155 Railway Certification	03
Voltage Isolation/Withstand Test for EN 50155 Railway Certification	04
Electromagnetic Capability (EMC) Test for EN 50155 Railway Certification	04-05
Environmental Requirement Test for EN 50155 Railway Certification	06-07
Mechanical Requirements Test for EN 50155 Railway Certification	08
Fire Protection Test of the EN 45545-2 Standard	09
HIGHLIGHTED PERFORMANCE OF RAILWAY CERTIFIED PRODUCTS	10

MINMAX RAILWAY CERTIFIED POWER SOLUTIONS

Successful Application	18
Railway Certified Products Overview	18
Railway Certified 3W DIP Package DC-DC Converters	19
Railway Certified 10-40W 2" x 1" Package DC-DC Converters	20-22
Railway Certified 50-150W Quarter Brick DC-DC Converters	23-26

► FUNDAMENTAL INTRODUCTION

- ◆ Trains and high-speed rail have become more technically advanced and passenger-friendly with many additional infotainment systems and critical safety equipment. These types of electrical systems and functions, such as monitoring sensors around the train; air conditioning; lighting; and door-opening, communication, and entertainment systems, will inherently include CPUs, DSPs, analog circuitry, and highly sensitive sensors, which all must be powered from the railway storage battery system within the train.
- ◆ Modern trains and high-speed rail achieve reductions in weight and space by using a vehicle battery voltage upto 72 V or 110 VDC, but most electronic equipment/systems require input voltages of 5, 12, 15, 24, and 54 VDC. Basically, there are many railway certified DC-DC converters between the electronic equipment/systems and train's storage battery to transform the basic 72 V or 110 VDC into 5, 12, 15, 24, and 54 VDC.
- ◆ Moreover, the train's storage battery is typically located within the drive train locomotive at the front or rear of the vehicle. Therefore, the DC voltage is supplied over long distances by a power cable to the electronic equipment/system. These long power-cable lengths can pick up electromagnetic disturbances, induced transient voltage spikes (caused by nearby lightning strikes), and power-line fluctuations. The train's storage battery is also used to drive starter motors, pumps, compressors, drivers, relay coils, and other switch gears. These and other high-power loads are connected to the alternator, generator, and transformers. The end result of this environment is an unstable, highly fluctuating, noisy power source. It can also cause the risk of dangerous energy shocks due to excess energy hazards such as electric shocks, transient voltage spikes, mechanical damage, shorts developing between PCB tracks, air gaps, arcing, and ground loops, which cause ignition and fire situations. Each of these situations will extremely impact/interfere with the train's electronic equipment/system, resulting in a failure. Thus, we conclude that high-performance, high-isolation (with reinforced insulation), high-robustness, reliable, rugged, durable, uninterruptible railway certified DC-DC converters between the electronic equipment/system and the train's storage battery are necessary for long-term stable operation of the train's equipment and systems.
- ◆ Therefore, MINMAX railway certified DC-DC converters between the train's storage battery and electronic equipment/system, which are integrated into train/rolling stock applications must comply with the international railway certification "**EN 50155:2017(IEC 60571): Railway Application Electronic Equipment Used on Rolling Stock.**" This certification covers specification requirements including the input voltage specification test, I/O voltage isolation test, insulation test, Electromagnetic Capability (EMC) test, mechanical requirement test, and harsh environmental test including the operating temperature test and the humidity, cooling, dry heat and damp heat tests that trains/rolling stock electronic equipment must meet.
- ◆ The right product is essential, but it is not everything. In addition to our product offerings, we provide a comprehensive range of services, including analysis and qualification in the development stage, demand planning and special logistics in the production phase, and end-user support in the aftermarket.
MINMAX aim to serve you with sincerity to ensure that your customers return time and again.

▶ INPUT VOLTAGE SPECIFICATION TEST FOR EN 50155:2017 RAILWAY CERTIFICATION

- ◆ In the case of railway certified DC-DC converters, the input port must interface with the train's storage battery power source. The standard specifies that the input-voltage range of the converters must be operated in the same range as the train's storage battery voltage during normal operation. A surge voltage test is specified to cover extreme variations, in addition to the minimum insulation requirements for safety.

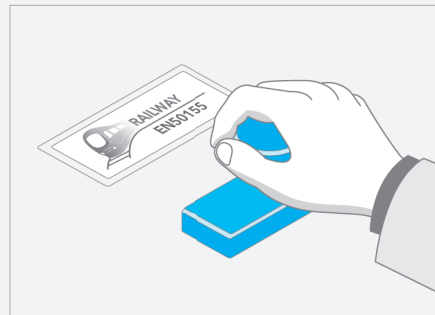

- ◆ Nominal DC input voltages (V_N) of 24, 36, 48, 72, 96, and 110 VDC are usually provided by the train's storage battery power sources used as the primary insulation barrier in the railway DC power architecture.
- ◆ MINMAX railway certified DC-DC converters powered directly from batteries with no voltage stabilizing device must function properly with input voltages that range from $0.7V_N$ to $1.25V_N$ during normal operation. Further, these converters also withstand input voltage drops of $0.6V_N$ for 100 ms and overvoltage surges of $1.4V_N$ for 1s that may occur during startup.

The table below summarizes, with some exceptions, the MINMAX railway certified DC-DC converters that cover all the specified input ranges, brown-outs, transients, and voltage spikes for the permanent operation of a train's electronic equipment system.

Phenomenon	EN 50155 : 2017 Reference Clause / Standard	
	Standard Test Level	MINMAX Test Level
Supply Variations	EN 50155 12.2.2 / EN 50155 5.1.1.1	
	Test Voltage / Time: $0.7 V_N$ / 10min.	Test Voltage / Time: $0.7 V_N$ / 10min.
	Test Voltage / Time: V_N / 10min.	Test Voltage / Time: V_N / 10min.
	Test Voltage / Time: $1.25 V_N$ / 10min.	Test Voltage / Time: $1.25 V_N$ / 10min.
	Test Voltage / Time: $0.6 V_N$ / 0.1sec.	Test Voltage / Time: $0.6 V_N$ / 1min.
	Test Voltage / Time: $1.4 V_N$ / 0.1sec.	Test Voltage / Time: $1.4 V_N$ / 1sec.
	Test Voltage / Time: $1.4 V_N$ / 1sec Test Number: repeated 10 times	Test Voltage / Time: $1.4 V_N$ / 1min. Test Number: repeated 10 times
Supply Interruptions	EN 50155 12.2.2 / EN 50155 5.1.1.2	
	Class S1: $100\%V_N$ / 0mS	Class S1: $100\%V_N$ / 0mS
	Class S2: $100\%V_N$ / 10mS Test Number: repeated 10 times	Class S2: $100\%V_N$ / 10mS* Test Number: repeated 10 times
Supply Change Over	EN 50155 12.2.2 / EN 50155 5.1.1.3	
	Class C1: Dip $40\%V_N$ / 100mS	Class C1: Dip $40\%V_N$ / 100mS & 10min.
	Class C2: Interruptions $100\%V_N$ / 30mS Test Number: repeated 10 times	Class C2: Interruptions $100\%V_N$ / 30mS* Test Number: repeated 10 times
Supply Over Voltages	EN 50155 12.2.6	
	Voltage Level / Duration: $1.4 V_N$ / 0.1sec	Voltage Level / Duration: $1.4 V_N$ / 10min.
	Voltage Level / Duration: $1.4 V_N$ / 1sec. Test Number: repeated 10 times	Voltage Level / Duration: $1.4 V_N$ / 60min. Test Number: repeated 10 times

*Note: Peripheral Components Needed, Please Contact MINMAX for More Information.

▶ VOLTAGE ISOLATION/WITHSTAND TEST FOR EN 50155:2017 RAILWAY CERTIFICATION

- ◆ Railway certified DC-DC converters have significantly played a crucial role in the certification of on-train electrical equipment.
- ◆ A 3000-VAC isolation/withstand voltage test with reinforced insulation of the MINMAX railway certified DC-DC converters will verify the design creepage, air clearances, and insulation level of the power module demands.

The above criteria comply with the limited leakage current under normal/single-fault conditions and protect sensitive circuit loads from noise, electromagnetic disturbances, power bus fluctuations, surges, electrical shocks, transient voltage spikes, insulation breakdown of the power architecture, mechanical damage, shorts developing between PCB tracks, air gaps, arcing, and ground loops, which cause ignition and fire situations.

Phenomenon	EN 50155 : 2017 Reference Clause	
	Standard Test Level	MINMAX Test Level
Isolation / Withstand Voltage Test	EN 50155 12.2.9	
	Test Voltage / Time: 2100VAC / 60sec.	Test Voltage / Time: 3000VAC / 60sec.

▶ ELECTROMAGNETIC CAPABILITY (EMC) TEST FOR EN 50155:2017 RAILWAY CERTIFICATION

- ◆ Electromagnetic compatibility (EMC) is another main category of the **EN 50155** certification.

MINMAX railway certified DC-DC converters are approved at the European **EN 50121-3-2** standard "Railways Applications Electromagnetic Compatibility Part 3-2 Rolling Stock Apparatus," which states that the power module should not emit conducted and radiated electromagnetic interference (EMI) in excess of the defined levels and should be protected from outside negative effects due to conduction, radiation, surges, ESD, and EFT interference.

► ELECTROMAGNETIC CAPABILITY (EMC) TEST FOR EN 50155:2017 RAILWAY CERTIFICATION

EMC	Phenomenon	EN 50155 : 2017 Reference Clause / Standard	
		Standard Test Level	MINMAX Test Level
EMI	Conducted Emission	EN 50155 12.2.8.2 / EN 50121-3-2, EN 55011 sub-clause 7	
		Frequency / level: 0.15~0.5MHz / 99 dBuV	Frequency / level: 0.15~0.5MHz / 66 dBuV*
		Frequency / level: 0.5~5MHz / 93 dBuV	Frequency / level: 0.5~5MHz / 60 dBuV*
		Frequency / level: 5~30MHz / 93 dBuV	Frequency / level: 5~30MHz / 60 dBuV*
Radiated Emission	EN 50155 12.2.8.2 / EN 50121-3-2, EN 55011 sub-clause 7		
	Frequency / level: 30~230MHz / 40 dB(uV/m)	Frequency / level: 30~230MHz / 40 dB(uV/m)*	
	Frequency / level: 230~1000MHz / 47 dB(uV/m)	Frequency / level: 230~1000MHz / 47 dB(uV/m)*	
EMS	ESD Immunity Test	EN 50155 12.2.7.2 / EN 50121-3-2, IEC 61000-4-2	
		Air Discharge: ±8KVDC	Air Discharge: ±8KVDC
		Contact Discharge: ±6KVDC	Contact Discharge: ±6KVDC
		Indirect Discharge HCP & VCP: ±6KVDC	Indirect Discharge HCP & VCP: ±2/4/6KVDC
	Radio-Frequency, Electromagnetic Field Immunity Test	EN 50155 12.2.8.1 / EN 50121-3-2, IEC 61000-4-3	
		Frequency / Field: 80~1000MHz/20 V/m	Frequency / Field: 27~80MHz/20 V/m
		Frequency / Field: 1400~2000MHz/10 V/m	Frequency / Field: 80~1000MHz/20 V/m
		Frequency / Field: 2000~2700MHz/5 V/m	Frequency / Field: 1400~2000MHz/20 V/m
		Frequency / Field: 5100~6000MHz/3 V/m	Frequency / Field: 2000~2700MHz/10 V/m
		Frequency / Field: 2700~5000MHz/10 V/m	Frequency / Field: 5100~6000MHz/10 V/m
Electrical Fast Transient/Burst Immunity Test	EN 50155 12.2.7.3 / EN 50121-3-2, IEC 61000-4-4		
	Line, Neutral, Line+Neutral: ±2KVDC	Line, Neutral, Line+Neutral: ±2KVDC*	
Surge Immunity Test	EN 50155 12.2.7.1 / EN 50121-3-2, IEC 61000-4-5		
	Line to Line: ±1KVDC	Line to Line: ±2KVDC*	
Radio-Frequency, Conducted Disturbances Immunity Test	EN 50155 12.2.8.1 / EN 50121-3-2, IEC 61000-4-6		
	Frequency : 0.15 to 80MHz	Frequency : 0.15 to 80MHz	
	Field: 10 Vrms	Field: 10 Vrms	
Power Frequency Magnetic Field Immunity Test	IEC 61000-4-8		
	No Needed	Frequency: 50Hz Field: 30/100/1000 A/m	
Damp Oscillatory Magnetic Field Immunity Test	IEC 61000-4-10		
	No Needed	Frequency: 0.1 & 1 MHz Field: 30 A/m	

*Note:Peripheral Components Needed, Please Refer to the Datasheet or Contact MINMAX for More Information.

► ENVIRONMENTAL REQUIREMENT TEST FOR EN 50155:2017 RAILWAY CERTIFICATION

◆ Operating Temperature Range Requirement

The operating temperatures are divided into four classes according to the severity of the environment, as summarized in the table below. When designing railway certified DC-DC converters, it is necessary to consider the over-temperature during startup, as indicated in the third column.

Table 1 - Operating Temperature Rating

Class	Equipment Operating Temperature Range (°C)
OT1	-25°C to +55°C
OT2	-40°C to +55°C
OT3	-25°C to +70°C
OT4	-40°C to +70°C
OT5	-25°C to +85°C
OT6	-40°C to +85°C

The OT5 and OT6 types cannot serve as the general specifications of temperature requirements for vehicles (but can be used in the semiconductor drive unit (SDU), engine control unit).

The OT1 and OT2 types are suitable for passenger compartments and driver's cab. The long-term temperature must be maintained at 25°C, while the temperature at the passenger compartments and driver's cab can affect the service life of the material. The OT3 and OT4 types are ideal for the equipment in the cabinets with a long-term reference temperature of 45°C. This ambient temperature can also affect the service life of the material.

- ◆ The indoor temperature rise should be considered during design phase to ensure that the temperature of the components will not exceed the specified rated temperature. For example, if the air temperature around the PCB rises by about 15°C (this temperature rise depends mainly on the power consumption of the PCB itself and the adjacent PCB, or the natural airflow, enforced airflow, etc.). While designing the PBA, we should consider placing one PBA horizontally or vertically; or allow the sub-racks of the PBA to be stacked together. The suppliers should consider the requirements imposed by specific onboard installations.

In some exceptional cases (such as partitions, effects of sunlight, the shutdown of the auxiliary cooling system), the additional operational checks on the switch-on equipment should be processed under a short-term thermal condition based on the status of ST1 or ST2 as shown in Table 2.

► ENVIRONMENTAL REQUIREMENT TEST FOR EN 50155:2017 RAILWAY CERTIFICATION

Table 2 - Switch-On Status of the Extended Operating Temperature Rating

Class	Switch-On Extended Operating Temperature (Duration: 10 min)
ST0	No Switch-On Extended Operating Temperature
ST1	OTx + 15°C
ST2	OTx + 15°C

Operating Temperature and Humidity Test

Phenomenon	EN 50155 : 2017 Reference Clause / MINMAX Test Level
Low Temperature Start-up Test	EN 50155 13.4.4 / EN 60068-2-1
	Test Curve Follow by EN 50155 : 2017 with: <ul style="list-style-type: none"> • Operating Temperature Class : OT4 • Continuous Operation Checks Period: 8 HRs
Dry Heat Test	EN 50155 13.4.5 / EN 60068-2-2
	Test Curve Follow by EN 50155 : 2017 with: <ul style="list-style-type: none"> • Operating Temperature Class: OT4 • Switch-On Extended Operating Temperature Range Class: ST2 • Thermal Test Cycle: C • Continuous Operational Checks Period: 8 HRs
Low Temperature Storage Test	EN 50155 13.4.6 / EN 60068-2-2
	Test Curve Follow by EN 50155 : 2017 with: <ul style="list-style-type: none"> • Temperature / Dwell Time: 16HRs in Storage
Cyclic Damp Heat Test	EN 50155 13.4.7 / EN 60068-2-30
	Test Curve Follow by EN 50155 : 2017 with: <ul style="list-style-type: none"> • Test Temperature (T_{TEST}) under Equip. Switched ON: +70°C • Continuous Operation Checks Period under Equip. Switched ON: 24HRs • Test Temperature (T_{TEST}) of Recovery Period under Equip. Switched OFF: +70°C

► MECHANICAL REQUIREMENTS TEST FOR EN 50155:2017 RAILWAY CERTIFICATION

Vibration and Increased Vibration Test

- ◆ The EN 50155 certification specifies that railway certified DC-DC converters mounted on boards and boxes fixed to the railway/railroad vehicle frame must be able to withstand and satisfy the stringent EN 61373 vibration and shock test. Therefore, the manufacturing processes must be rigorously controlled to ensure consistent performance.

The entire process requires dedication and commitment to serve the special needs of rolling-stock on board electronics.

MINMAX railway certified DC-DC converters have been specially designed for high shock and vibration tolerances are able to withstand, without deterioration or malfunction, such conditions in compliance with EN 61373 standards.

Phenomenon	EN 50155 : 2017 Reference Clause / Standard	
	Standard Test Level	MINMAX Test Level
Functional Random Vibration Test	EN 50155 12.2.11 / EN 61373 (EN 60068-2-6)	
	Category 1, Class B, Body Mounted Frequency Range: 5Hz~150Hz Grms Value: 0.102 Grms (1.0/s ²) for Each Axis Dwell Time: 10min/axis in Storage	Category 3, Axle Mounted Frequency Range: 5Hz~150Hz Grms Value: 5.102 Grms (50m/s ²) for Each Axis Dwell Time: 10min/axis in Operation
Increased Random Vibration Test	EN 50155 12.2.11 / EN 61373 (EN 60068-2-6)	
	Category 1, Class B, Body Mounted Frequency Range: 5Hz~150Hz Grms Value: 0.806 Grms (7.9m/s ²) for Each Axis Dwell Time: 5 HRs/axis in Storage	Category 2, Bogie Mounted Frequency Range: 5Hz~150Hz Grms Value: 5.102 Grms (50m/s ²) for Each Axis Dwell Time: 5 HRs/axis in Operation
Shock Test	EN 50155 12.2.11 / EN 61373 (EN 60068-2-27)	
	Category 1, Class A&B, Body Mounted Wave Form: Half-Sine Acceleration Peak: 5.102 Grms (50m/s ²) for Each Axis Dwell Time: 30mS in Storage Shock/Bump Times: 3 Times for Each Direction	Category 3, Axle Mounted Wave Form: Half-Sine Acceleration Peak: 5.102 Grms (50m/s ²) for Each Axis Dwell Time: 30mS in Operation Acceleration Peak: 10 Grms (100m/s ²) for Each Axis Dwell Time: 11mS in Operation Acceleration Peak: 100 Grms (1000m/s ²) for Each Axis Dwell Time: 6mS in Operation Shock Times: 3 Times for Each Direction
Bump Test	No Reference / No Reference (EN 60068-2-29)	
	No Needed	Wave Form: Half-Sine Acceleration Peak: 5.102 Grms (50m/s ²) for Each Axis Dwell Time: 30mS in Operation Acceleration Peak: 10 Grms (100m/s ²) for Each Axis Dwell Time: 11mS in Operation Bump Times: 2000Bumps for Each Direction

► FIRE PROTECTION TEST OF THE EN 45545-2 STANDARD

- ◆ The railway/railroad transportation industry generally requires power module materials to meet the relevant requirements of the EN 45545-2 fire protection test standard. The EN 45545-2 guidelines specify that different materials under test shall be classified, and their “fire safety index parameter and test conditions” are defined according to different categories of R1-R26.

Test Content :

1. Functional descriptions of fire-safe samples
2. Fire safety requirements for homogeneous materials
3. Component materials of the internal structure

The following index parameters are used to evaluate the fire protection capabilities :

Heat release rate, Combustibility, Smoke toxicity, Smoke opacity

- ◆ The fire protection grades (HL Levels) of the different materials under test will be evaluated on the basis of the final test data of the “fire safety index parameter”.
- ◆ The fire protection grades of the materials required for railway/railroad vehicles will be classified according to the vehicle’s operating environment and different vehicle categories and by referencing the table below (Table 1 - Hazard Level Classification).

Table 1-Hazard Level Classification

Operation category	Design category			
	N : Standard vehicles	A : Vehicles forming part of an automatic train having no emergency trained staff on board	D : Double decked vehicles	S : Sleeping and couchette vehicles
1	HL1	HL1	HL1	HL2
2	HL2	HL2	HL2	HL2
3	HL2	HL2	HL2	HL3
4	HL3	HL3	HL3	HL3

► FIRE PROTECTION TEST OF THE EN 45545-2 STANDARD

Operation Category 1

Vehicles for operation on infrastructure where railway vehicles may be stopped with minimum delay, and where a safe area can always be reached immediately.

Operation Category 2

Vehicles for operation on underground sections, tunnels and/or elevated structures, with side evacuation available and where there are stations or rescue stations that offer a place of safety to passengers, reachable within a short running time.

Operation Category 3

Vehicles for operation on underground sections, tunnels and/or elevated structure, with side evacuation available and where there are stations or rescue stations that offer a place of safety to passengers, reachable within a long running time.

Operation Category 4

Vehicles for operation on underground sections, tunnels and/or elevated structure, without side evacuation available and where there are stations or rescue stations that offer a place of safety to passengers, reachable within a short running time.

- ◆ The fire protection grades (HL Levels) of all plastic housings, printed circuit boards (PCBs), and potting compounds of all MINMAX’s railway certified power modules will be evaluated on the basis of the final test results of the “fire safety index parameter” to ensure safety during railway/railroad vehicle operation.

HIGHLIGHTED PERFORMANCE OF RAILWAY CERTIFIED PRODUCTS



▶ Ultra-wide Input Voltage Range

- ◆ Using wide 4:1 input voltage range for railway DC bus with 24V, 36V, 48V, 72V, 96V, 110VDC easily (MKZI20 series as example).

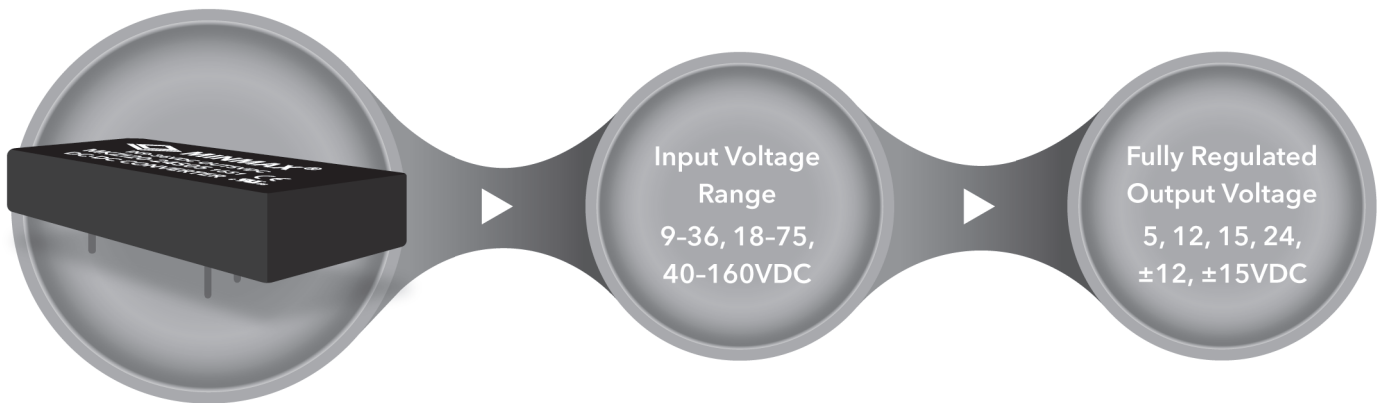

* Example : MKZI20-110S12

* Please refer to the "Input Voltage Specification Test for EN 50155 Railway Certification" on Page 03 for more information.

▶ Fully Vacuum Encapsulated & Fire Protection Test to Save Your System

- ◆ **MINMAX railway certified DC-DC converters** are fully vacuum encapsulated and use the glue of UL 94V-0 grade.

MTBF>1Million HRs

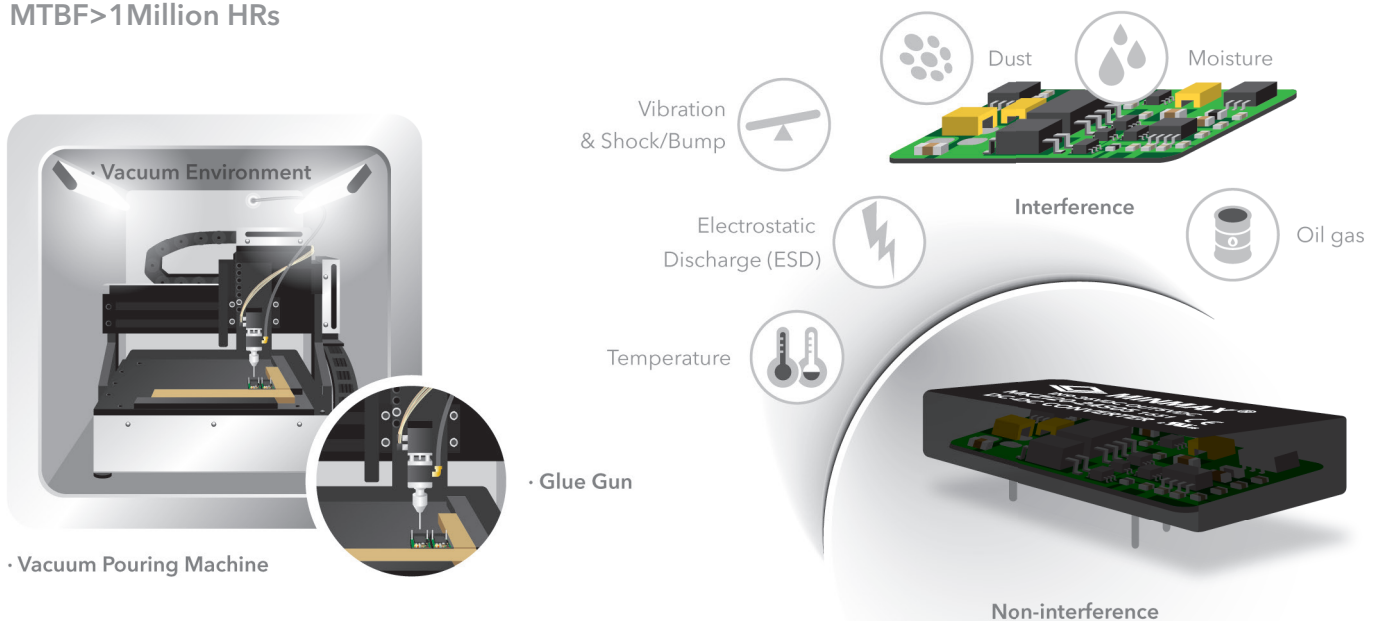

* Example : MKZI20-110S12

* Please refer to the "Environmental & Mechanical Requirement Test for EN 50155 Railway Certification" on Page 06-08 for more information.

► Fully Encapsulated & Fire Protection Test to Save Your System

Fire Protection Test

◆ The following index parameters are used to evaluate fire protection capabilities:

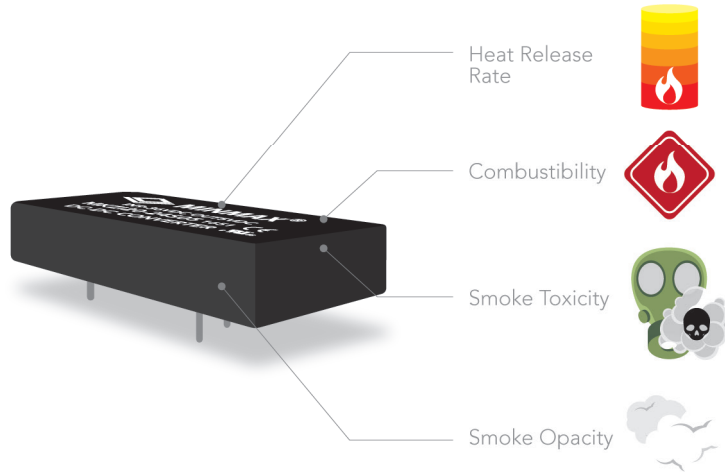

◆ Fire protection grades (HL Level) of all plastic housings, printed circuit boards (PCB), and potting compounds of all MINMAX's railway certified power modules will be evaluated based on the final test results of the "fire safety index parameter" to ensure safety during railway/railroad vehicle operation.

* Please refer to the "Fire Protection Test of the EN 45545-2 Standard" on Page 09 for more information.

► Primary Reinforced Insulation Barrier with Patent Insulated Frame for Strength Railway Power Architecture

◆ The MINMAX railway certified DC-DC power modules have been verified by UL organization that transient rating test for Reinforced Insulation Barrier of PRIMARY CIRCUIT is based on : (1) 160VDC input voltage, not only 110VDC input voltage (2) Highest 3000VAC Isolation (3) Working Voltage of 1000Vrms.

◆ The MINMAX railway certified DC-DC power modules applied for the power distribution system that is either an AC MAINS SUPPLY or a DC MAINS SUPPLY both available.

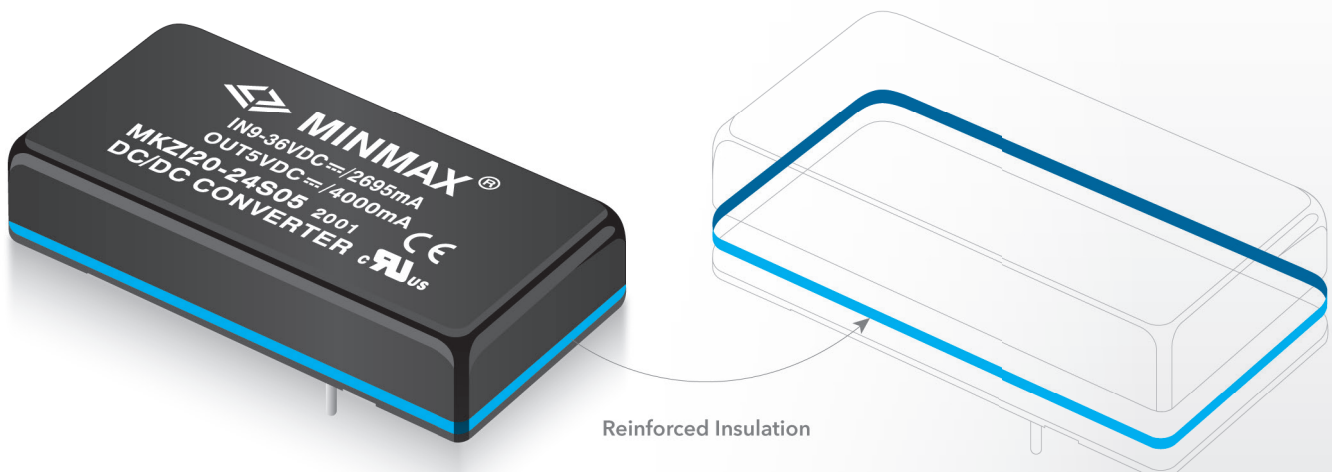

* Example : MKZI20-110S12

► Reinforced Insulation & 3KVAC Isolation for System Safety

- ◆ The 3KVAC I/O isolation with reinforced insulation and vacuum encapsulated creates a solid electrical barrier which to protect sensitive circuit load from noise, electromagnetic disturbances, power bus fluctuation, surge, electric shock, transient voltage spike, insulation breakdown of power architecture, mechanical damage and short developing between PCB tracks, air gaps, arcing and ground loop. Thus provide safety on long-term operation of railway/railroad equipment.

* Please refer to the "Voltage Isolation/Withstand Test for EN 50155 Railway Certification" on Page 04 for more information.

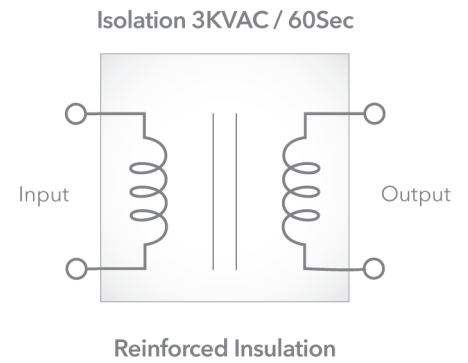

► Wider Operating Ambient Temperature Range

- ◆ Wide operating temp. range by latest thermal management technology and fully vacuum encapsulated.

Wider Operating Temp. Range

-40 to +88.5°C without air-forced fan or heatsink cooling

Storage Temp. Range

-50 to +125°C

Operating Humidity

95% rel. H

* Please refer to the "Environmental Requirement Test for EN 50155 Railway Certification" on Page 06 & 07 for more information.

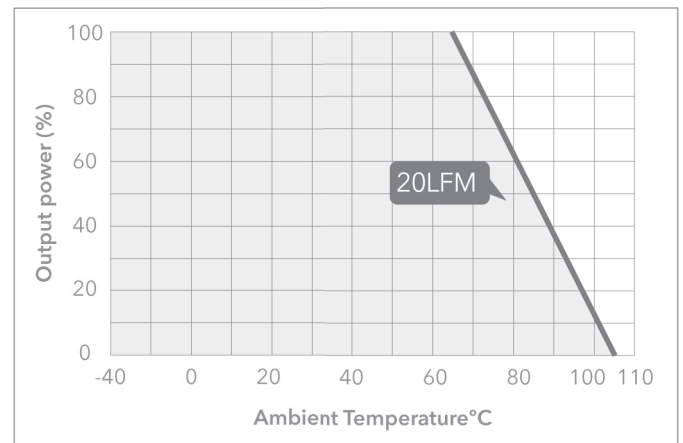

* Example : MKZI20-110S12

► Altitude by 5000 Meters for Plain to Plateau Operation

- ◆ Certified by UL standards of safety to withstand an altitude of 5000m.

Avoids short circuit development between PCB tracks, air gaps and arcing, to solve the high-altitude operation-limit issues of your train.

* Example : MKZI20-110S12

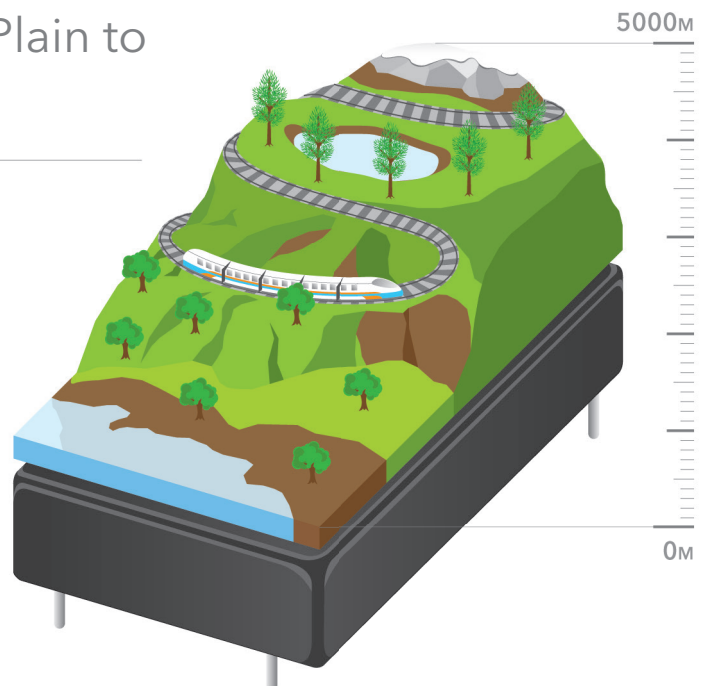

► MINMAX Reliability Test

- ◆ Besides EN 50155 standard, our railway DC-DC converters are tested by conscientious and reliable to provide high quality and safe products.

Testing Characteristics	Testing Condition	
Developing Product Reliability Test		
Burn-in	Input Line Output Load Temperature Duration	Nom. Line Full Load Room Temperature 1032 HRs
Highly Accelerated Life Test(HALT)	Thermal Step Stress Test Rapid Thermal Stress Test Vibration Step Stress Test Combined Environmental Stress Test	
Temperature Cycling Test(TCT)	Temperature Change Steady State Duration Ramp Rate Number of Cycles	-40°C ~ +125°C 30min 20°C/min 200+
Temperature & Humidity Storage Cycling Test (Non-Operation)	Temperature Change Ramp Rate Relative Humidity Steady State Duration Number of Cycles	Low to High Temperature 1-3°C/min +95% RH. 1 HR 5 Cycles
Power and Temperature Cycling Test(PTCT) (In Operation)	Input Line Change Output Load Change Temperature Change Relative Humidity Duration for ON/OFF Number of Cycles	Low/Nom./High Line No or Min./Full Load Low to High Temperature +95% RH. 3 Sec 300 Cycles
Temperature, Humidity and Bias Test(THB) (In Operation)	Input Line Output Load Temperature Relative Humidity Operating Duration	High Line No or Min. Load +85°C +85% RH. 1000 HRs
Low Temperature Test (In Operation)	Input Line Output Load Temperature Duration	Nom. Line Full Load Low Temperature Achieve Thermal Equilibrium
High Temperature Test (In Operation)	Input Line Output Load Temperature Duration	Nom. Line Full Load High Temperature Achieve Thermal Equilibrium
Vibration Test (Non-Operation)	Waveform	Random
	P.S.D Level	10 Hz · 1.04×10 ⁻³ g ² /Hz 30 to 200Hz · 20.8×10 ⁻³ g ² /Hz 500 Hz · 2.08×10 ⁻³ g ² /Hz
	Duration	30 minutes
	Directions	X, Y and Z
Shock Test (Operation)	Waveform Acceleration Duration Number of Shocks	Half-sine 30 g 11 ms 3 shocks for each ±axis
ESD Test	Contact Discharge Air Discharge	±4KV ±2/4/8KV
Soldering Heat Test	MIL-STD-202F Method 210E	
RoHS	RoHS Directive 2011/65/EU	
Additional Test		
Drop Test	Drop Height	66 cm
	Drop Sequence	1 corner, 3 edges and 6 faces



▶ Green Design for Higher Full Range Efficiency

- High efficiency for whole output load, input line & ambient temp. range by latest green design technology helps to energy saving, thermal management, minimize the temp. rise and size miniaturization.

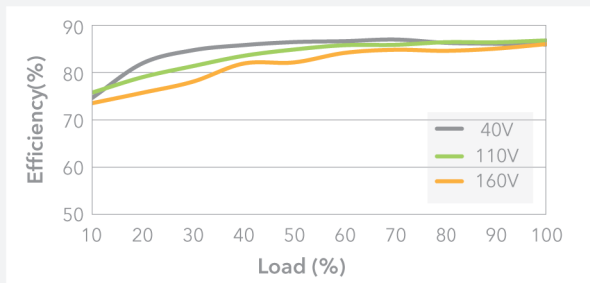

* Example : MKZI20-110S12

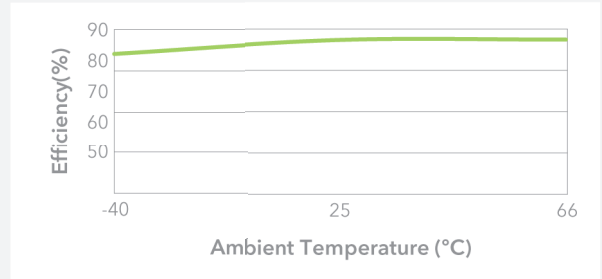

* Example : MKZI20-110S12 @ Nom. Line & 100% Load

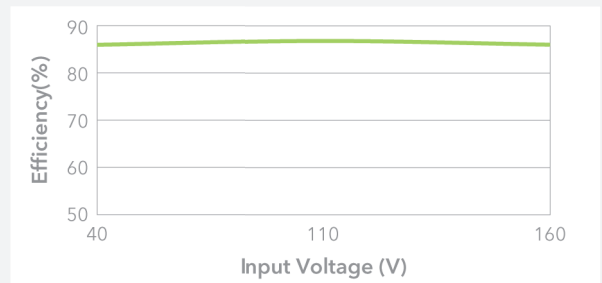

* Example : MKZI20-110S12 @ 100% Load

▶ Green Design for Energy Saving, Minimize Temperature Rise

- Ultra low no-load power consumption by latest green design technology helps to improve and minimize the temp. rise (avoid thermal problem), energy saving and prolong the battery life.

Very Low No Load Input Current 2mA @ 110Vin

Very Low No Load Power Consumption 0.2Watt @ 110Vin

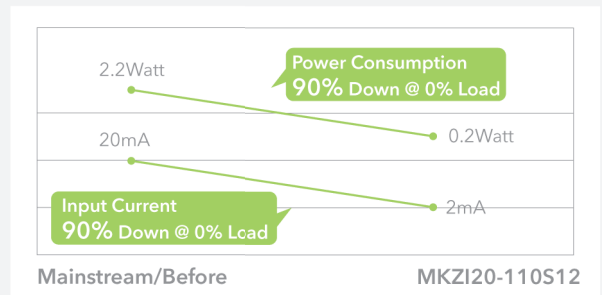

▶ Green Design for No Min. Load / Dummy Load Requirement

- With high stability feedback loop design, the MINMAX railway certified DC-DC converters will not oscillate in no-load or light-load condition.

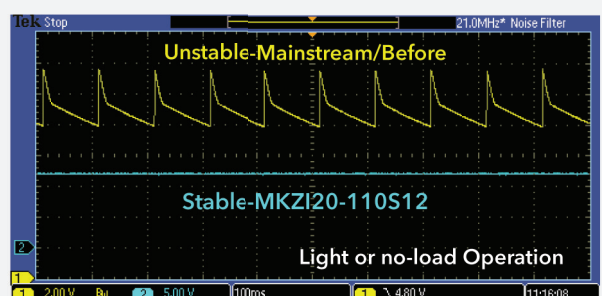

► Power Your System Precisely

Setting Accuracy $\pm 1\%$ Vom • Line Regulation $\pm 0.2\%$ • Load Regulation $\pm 0.5\%$ • High Transient Response • Low Temperature Coefficient

- ◆ The output voltage will still keep with excellent accuracy, even though the input voltage, output current and ambient temp. of the system are unstable .
- ◆ The output voltage of mainstream products may undershoot and overshoot obviously during the load changes.
MINMAX railway certified DC-DC converters still keep with rated output voltage precisely.

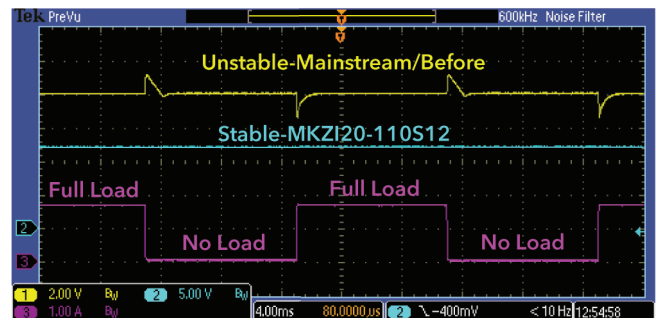

► Faster Start-up Time without Overshoot

- ◆ The start-up time of MKZI20 decreases from 250mS to 20mS which helps to avoid any system timing failure caused by long start-up time.
- ◆ Faster start-up time without overshoot ensures the safety of your system.

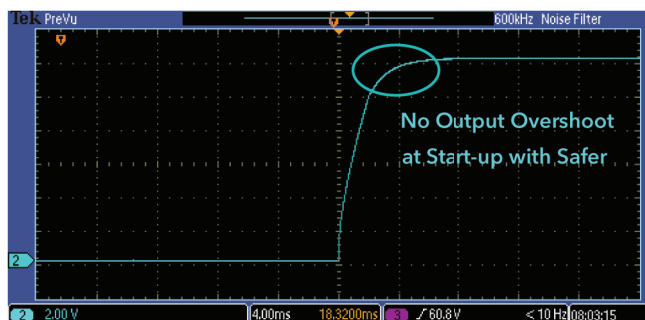
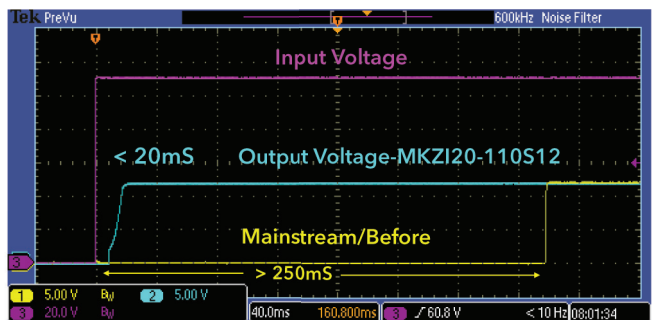

* Example : MKZI20-110S12

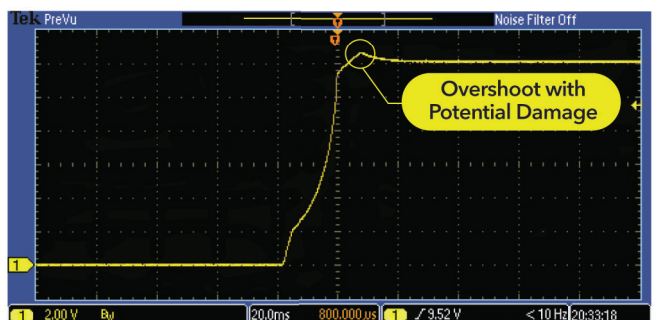

* Example : Mainstream/Before

► Superior Load Driving Capability

- ◆ MINMAX railway certified DC-DC converters have superior load driving capability which can drive your system during very low voltage and even zero voltage output without start-up failure.

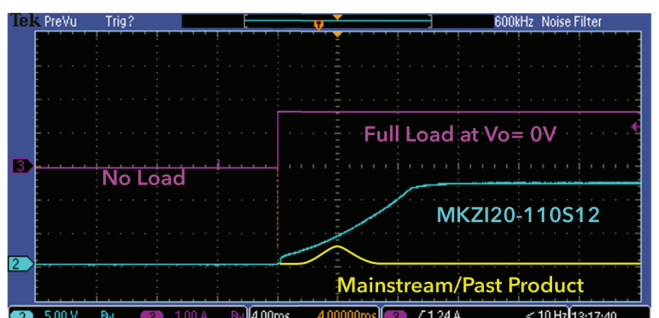

▶ Excellent EMC Performance

Excellent EMI performance by upgraded noise filtering technology helps to improve overall system EMI performance on conduction and radiation emission.

- ◆ No external component needed for conducted emission meets EN 55011 Class A.
- ◆ Only few peripheral components needed for radiated emission meets EN 55011 Class B.

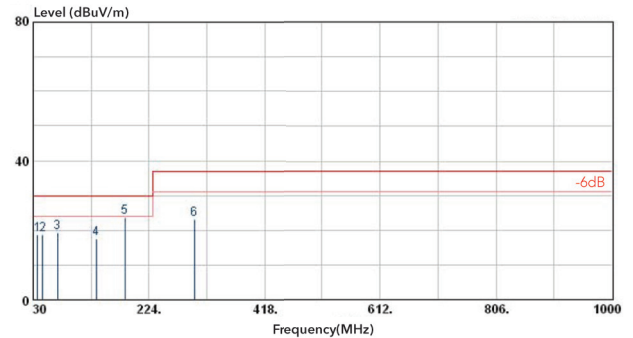
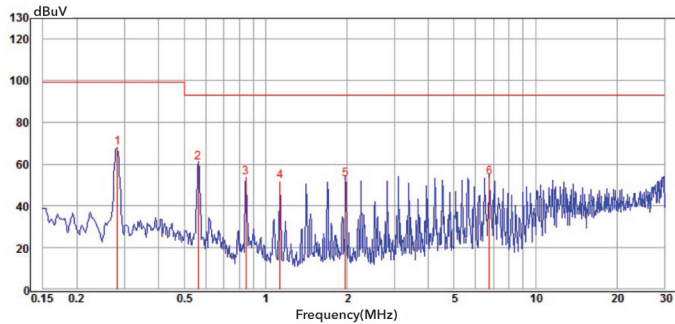

Excellent EMS performance by upgraded noise immunity technology helps to improve overall system EMS performance on ESD, Surge, EFT, RS, CS and PFMF.

- ◆ Only one E-cap. needed for ± 2 KV surge immunity by IEC 61000-4-5 with criteria A
- ◆ Only one E-cap. needed for ± 2 KV EFT immunity by IEC 61000-4-4 with criteria A.

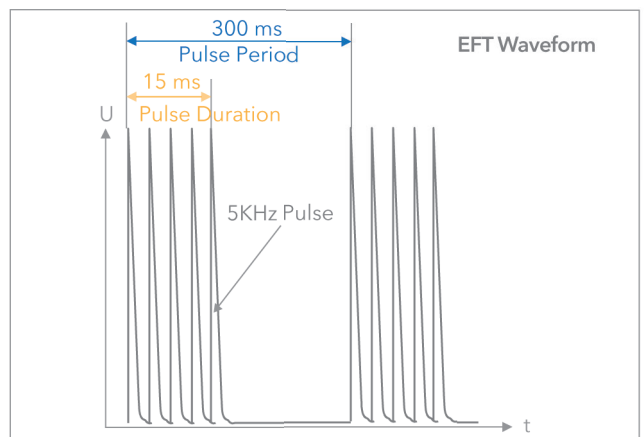
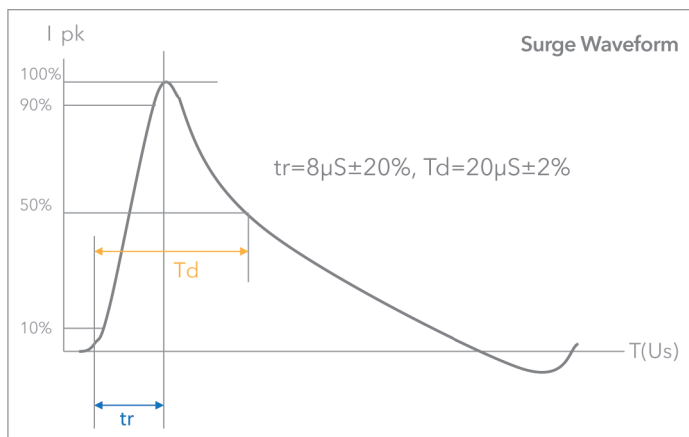

* Example : MKZI20

* Please refer to the "Electromagnetic Capability (EMC) Test for EN 50155 Railway Certification" on Page 04-05 for more information.

▶ Lower Ripple & Noise

- ◆ Small Ripple & Noise for whole output load, input line & ambient temp. range by upgraded noise filtering technology helps to reduce the peripheral components needed and noise interference.

* Example : MKZI20

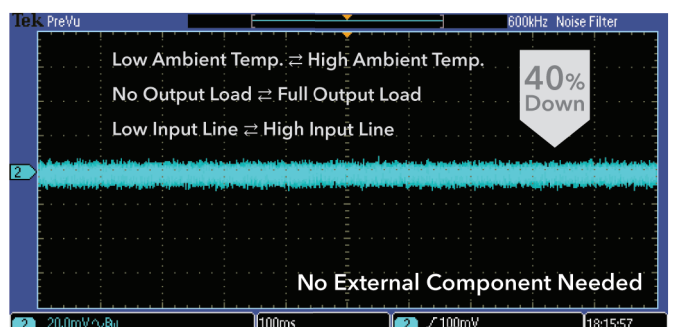

► Protection Functions on Abnormal Operation

- ◆ MINMAX railway certified DC-DC converters are the instantaneous protection for UVP, OCP, OVP & SCP which help to ensure long-term safety of system operation.

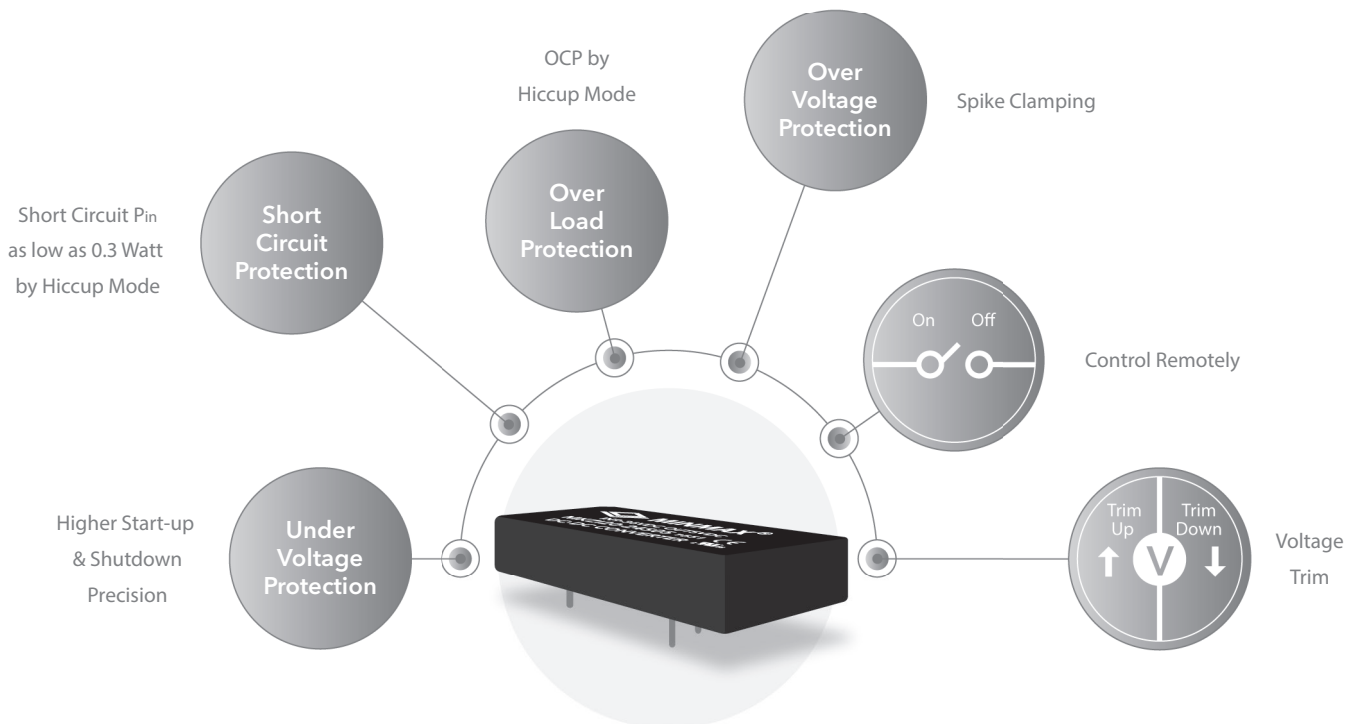

► Remote Control & Voltage Trim

- ◆ MINMAX railway certified DC-DC converters can be switched on/off remotely via the remote control function and trim up/down on output voltage via the trim function to increase your design flexibility and freedom.

► Certifications

- ✓ Railway Certified EN 50155 (IEC 60571) Approved
- ✓ Fire Protection Test EN 45545-2 Approved
- ✓ Vibration and Shock Test EN 61373 Approved
- ✓ Cooling, Dry & Damp Heat Test IEC/EC 60068-2-1, 2, 30 Approved
- ✓ Railway EMC Standard EN 50121-3-2 Approved
- ✓ CE Marking
- ✓ UL/cUL/IEC/EN 62368-1(60950-1) Approved

*Depends on series

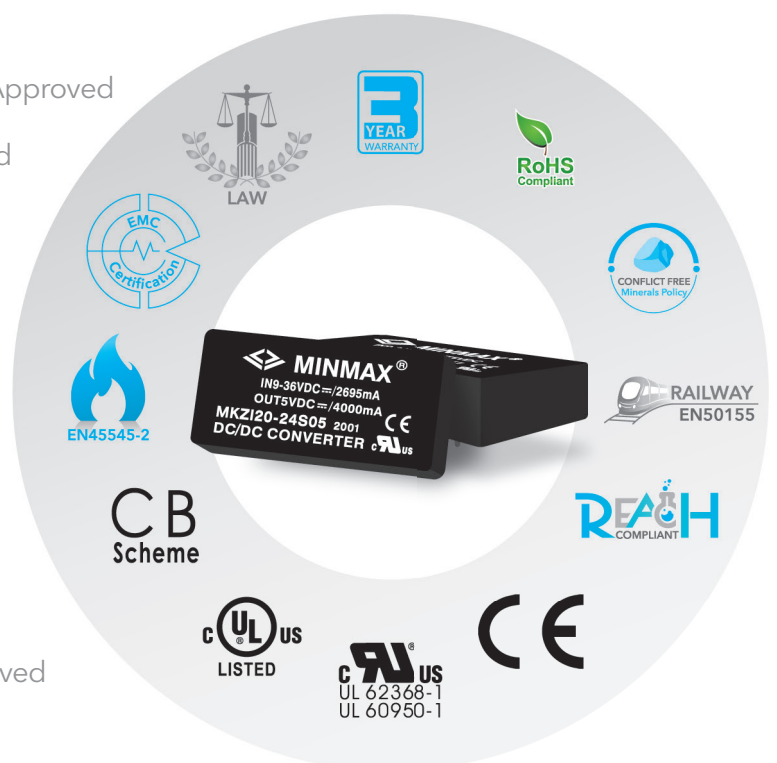

► Successful Application

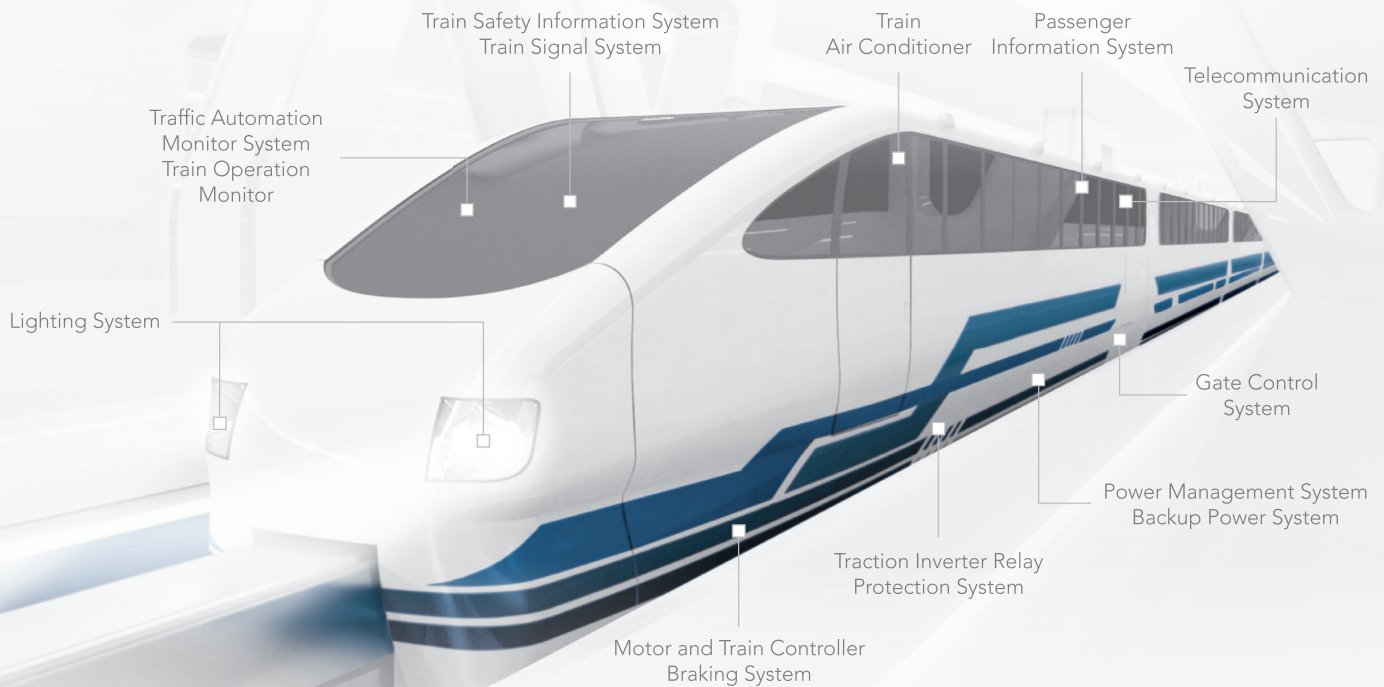

► Railway Certified Products Overview

Series	Output Power	Input Voltage Range (VDC)	Output Voltage (VDC)	Isolation (VAC)	Efficiency	Operating Temp. Range	No Min. Load	OCP/SCP	OVP	OTP	Remote ON/OFF Control	Output Voltage Trim	Output Sense	EN50155 (IEC60571)	UL/cUL/IEC/EN 62368-1
3W • DIP Package															
NEW MIZI03	3W	9-36 18-75 40-160	5, 12, 15, ±12, ±15	3000VAC Reinforced	85%	-40~+92°C Ambient	•	•						•	•
10-40W • 2" x 1" Package															
MKZI10	10W	9-36 18-75 40-160	5, 12, 15, 24, ±12, ±15	3000VAC Reinforced	89%	-40~+95°C Ambient	•	•	•		•	•		•	•
MKZI20	20W	9-36 18-75 40-160	5, 12, 15, 24, ±12, ±15	3000VAC Reinforced	88%	-40~+88.5°C Ambient	•	•	•		•	•		•	•
NEW MKZI40	40W	36-160	5, 12, 15, 24, 54, ±12, ±15	3000VAC Reinforced	90%	-40~+85.5°C Ambient	•	•	•		•	•		•	•
50-150W • Quarter Brick															
MTQZ50	50W	43-101 66-160	5, 12, 15, 24	3000VAC Reinforced	92%	-40~+85°C Ambient	•	•	•	•	•	•	•	•	•
MTQZ75	75W	43-101 66-160	5, 12, 15, 24	3000VAC Reinforced	92%	-40~+80°C Ambient	•	•	•	•	•	•	•	•	•
NEW MTQZI100	100W	40-160	5, 12, 15, 24, 54	3000VAC Reinforced	91.5%	-40~+105°C Base plate	•	•	•	•	•	•	•	•	•
NEW MTQZI150	150W	40-160	5, 12, 15, 24, 54	3000VAC Reinforced	90%	-40~+105°C Base plate	•	•	•	•	•	•	•	•	•

► Railway Certified • DC-DC Converters

3W

MIZI03 Series **NEW**



EMC and Environment Testing

- EN 50121-3-2 EMC Standard
- EN 61373 Vibration and Shock/Bump
- IEC/EN 60068-2-1, 2, 30 Cooling, Dry & Damp Heat
- EN 45545-2 Fire Protection

Vout 5, 12, 15, ±12, ±15VDC

I/O Isolation 3000VAC
Reinforced Insulation

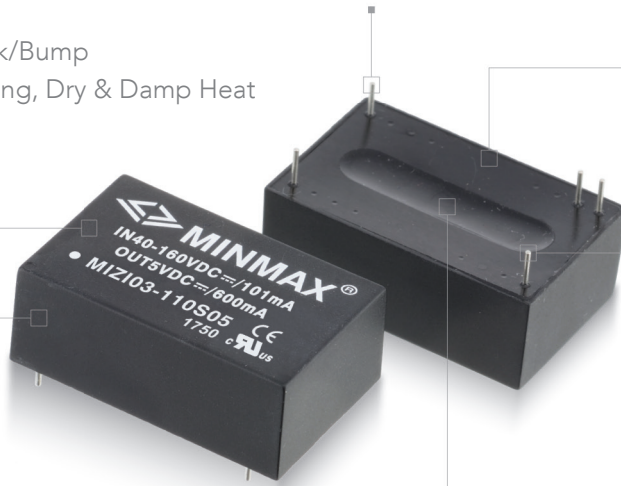

Vin
9-36VDC
18-75VDC
40-160VDC

Protection

- Under Voltage Protection
- Overload Protection
- Short Circuit Protection

Operating Ambient Temp.
-40°C to +92°C

Features

- ◆ Industrial Standard DIP-24 Package
- ◆ Ultra-wide Input Ranges 9-36VDC, 18-75VDC, 40-160VDC
- ◆ I/O Isolation 3000VAC with Reinforced Insulation
- ◆ Operating Ambient Temp. Range -40°C to +92°C
- ◆ No Min. Load Requirement
- ◆ Under-Voltage, Overload and Short Circuit Protection
- ◆ EMI Emission EN 55032/11 Class A & FCC Level A Approved
- ◆ Vibration and Shock/Bump Test EN 61373 Approved
- ◆ Cooling, Dry & Damp Heat Test IEC/EN 60068-2-1, 2, 30 Approved
- ◆ Railway EMC Standard EN 50121-3-2 Approved
- ◆ Railway Certified EN 50155 (IEC 60571) Approved
- ◆ Fire Protection Test EN 45545-2 Approved
- ◆ UL/cUL/IEC/EN 62368-1(60950-1) Safety Approval & CE Marking

Model Selection Guide

Model Number	Input Voltage (VDC)	Output Voltage (VDC)	Output Current (mA)max	Efficiency
MIZI03-24S05	24 (9 - 36)	5	600	80%
MIZI03-24S12		12	250	84%
MIZI03-24S15		15	200	85%
MIZI03-24D12		±12	±125	83%
MIZI03-24D15		±15	±100	84%
MIZI03-48S05	48 (18 - 75)	5	600	80%
MIZI03-48S12		12	250	83%
MIZI03-48S15		15	200	84%
MIZI03-48D12		±12	±125	83%
MIZI03-48D15		±15	±100	83%
MIZI03-110S05	110 (40 - 160)	5	600	80%
MIZI03-110S12		12	250	84%
MIZI03-110S15		15	200	84%
MIZI03-110D12		±12	±125	83%
MIZI03-110D15		±15	±100	85%

*There are different features & spec. by each series.
For detailed series datasheet, please refer to www.minmax.com.tw

► Railway Certified • DC-DC Converters

10W

MKZI10 Series



EMC and Environment Testing

- EN 50121-3-2 EMC Standard
- EN 61373 Vibration and Shock/Bump
- IEC/EN 60068-2-1,2,30 Cooling, Dry & Damp Heat
- EN 45545-2 Fire Protection

Protection

- Under Voltage Protection
- Overload Protection
- Over Voltage Protection
- Short Circuit Protection

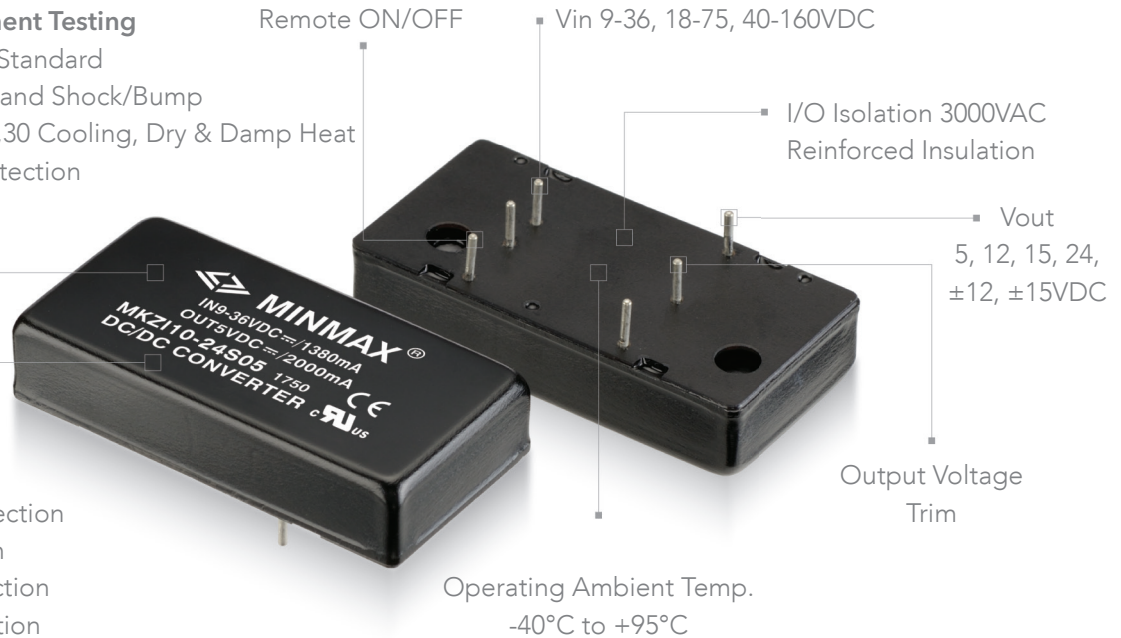

Features

- ◆ Industrial Standard 2" x 1" Package
- ◆ Ultra-wide Input Range 9-36VDC, 18-75VDC, 40-160VDC
- ◆ I/O Isolation 3000VAC with Reinforced Insulation
- ◆ Operating Ambient Temp. Range -40°C to +95°C
- ◆ No Min. Load Requirement
- ◆ Under-Voltage, Overload/Voltage and Short Circuit Protection
- ◆ Remote On/Off Control, Output Voltage Trim
- ◆ Conducted EMI EN 55032/11 Class A & FCC Level A Approved
- ◆ Vibration and Shock/Bump Test EN 61373 Approved
- ◆ Cooling, Dry & Damp Heat Test IEC/EN 60068-2-1, 2, 30 Approved
- ◆ Railway EMC Standard EN 50121-3-2 Approved
- ◆ Railway Certified EN 50155 (IEC 60571) Approved
- ◆ Fire Protection Test EN 45545-2 Approved
- ◆ UL/cUL/IEC/EN 62368-1 (60950-1) Safety Approval & CE Marking

Model Selection Guide

Model Number	Input Voltage (VDC)	Output Voltage (VDC)	Output Current (mA)max	Efficiency
MKZI10-24S05	24 (9 - 36)	5	2000	84%
MKZI10-24S12		12	835	86%
MKZI10-24S15		15	670	87%
MKZI10-24S24		24	417	88%
MKZI10-24D12	48 (18 - 75)	±12	±417	86%
MKZI10-24D15		±15	±335	87%
MKZI10-48S05		5	2000	85%
MKZI10-48S12		12	835	87%
MKZI10-48S15	110 (40 - 160)	15	670	87%
MKZI10-48S24		24	417	86%
MKZI10-48D12		±12	±417	89%
MKZI10-48D15		±15	±335	88%
MKZI10-110S05	110 (40 - 160)	5	2000	82%
MKZI10-110S12		12	835	85%
MKZI10-110S15		15	670	85%
MKZI10-110S24		24	417	85%
MKZI10-110D12	110 (40 - 160)	±12	±417	86%
MKZI10-110D15		±15	±335	86%

*There are different features & spec. by each series. For detailed series datasheet, please refer to www.minmax.com.tw

► Railway Certified • DC-DC Converters

20W

MKZI20 Series



EMC and Environment Testing

- EN 50121-3-2 EMC Standard
- EN 61373 Vibration and Shock/Bump
- IEC/EN 60068-2-1,2,30 Cooling, Dry & Damp Heat
- EN 45545-2 Fire Protection

Protection

- Under Voltage Protection
- Overload Protection
- Over Voltage Protection
- Short Circuit Protection

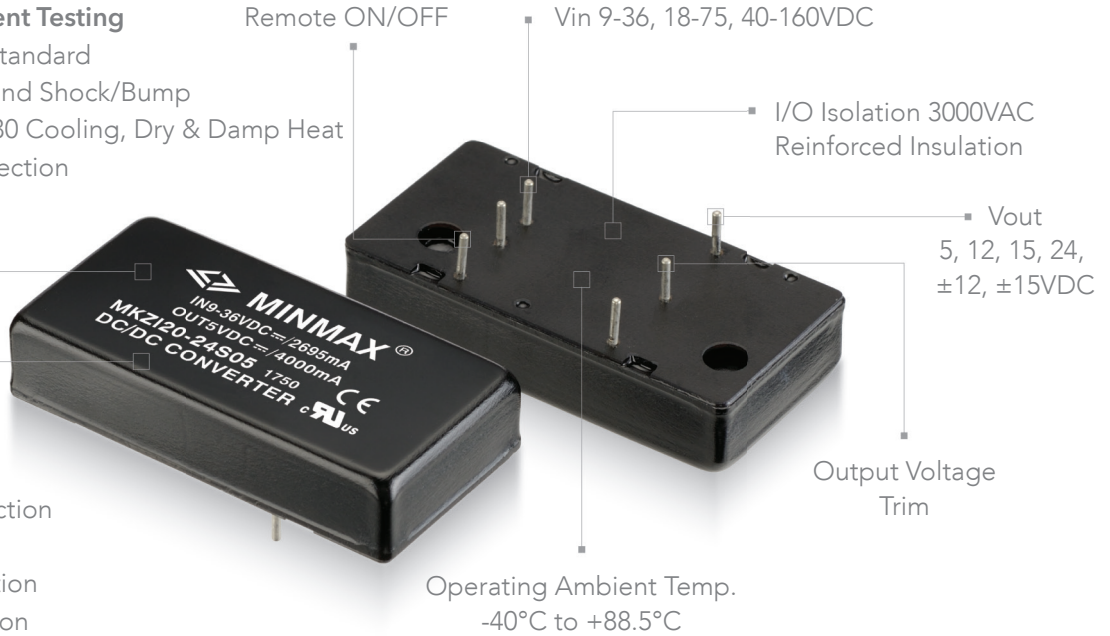

Features

- ◆ Industrial Standard 2" x 1" Package
- ◆ Ultra-wide Input Range 9-36VDC, 18-75VDC, 40-160VDC
- ◆ I/O Isolation 3000VAC with Reinforced Insulation
- ◆ Operating Ambient Temp. Range -40°C to +88.5°C
- ◆ No Min. Load Requirement
- ◆ Under-Voltage, Overload/Voltage and Short Circuit Protection
- ◆ Remote On/Off Control, Output Voltage Trim
- ◆ Conducted EMI EN 55032/11 Class A & FCC Level A Approved
- ◆ Vibration and Shock/Bump Test EN 61373 Approved
- ◆ Cooling, Dry & Damp Heat Test IEC/EN 60068-2-1, 2, 30 Approved
- ◆ Railway EMC Standard EN 50121-3-2 Approved
- ◆ Railway Certified EN 50155 (IEC 60571) Approved
- ◆ Fire Protection Test EN 45545-2 Approved
- ◆ UL/cUL/IEC/EN 62368-1 (60950-1) Safety Approval & CE Marking

Model Selection Guide

Model Number	Input Voltage (VDC)	Output Voltage (VDC)	Output Current (mA)max	Efficiency
MKZI20-24S05	24 (9 - 36)	5	4000	87%
MKZI20-24S12		12	1670	87%
MKZI20-24S15		15	1330	87%
MKZI20-24S24		24	833	87%
MKZI20-24D12	48 (18 - 75)	±12	±833	86%
MKZI20-24D15		±15	±667	86%
MKZI20-48S05		5	4000	87%
MKZI20-48S12		12	1670	88%
MKZI20-48S15	110 (40 - 160)	15	1330	88%
MKZI20-48S24		24	833	88%
MKZI20-48D12		±12	±833	87%
MKZI20-48D15		±15	±667	87%
MKZI20-110S05	110 (40 - 160)	5	4000	84%
MKZI20-110S12		12	1670	86%
MKZI20-110S15		15	1330	86%
MKZI20-110S24		24	833	86%
MKZI20-110D12	110 (40 - 160)	±12	±833	86%
MKZI20-110D15		±15	±667	86%

*There are different features & spec. by each series. For detailed series datasheet, please refer to www.minmax.com.tw

► Railway Certified • DC-DC Converters

40W

MKZI40 Series **NEW**



EMC and Environment Testing

- EN 50121-3-2 EMC Standard
- EN 61373 Vibration and Shock/Bump
- IEC/EN 60068-2-1,2,30 Cooling, Dry & Damp Heat
- EN 45545-2 Fire Protection

Protection

- Under Voltage Protection
- Overload Protection
- Over Voltage Protection
- Short Circuit Protection

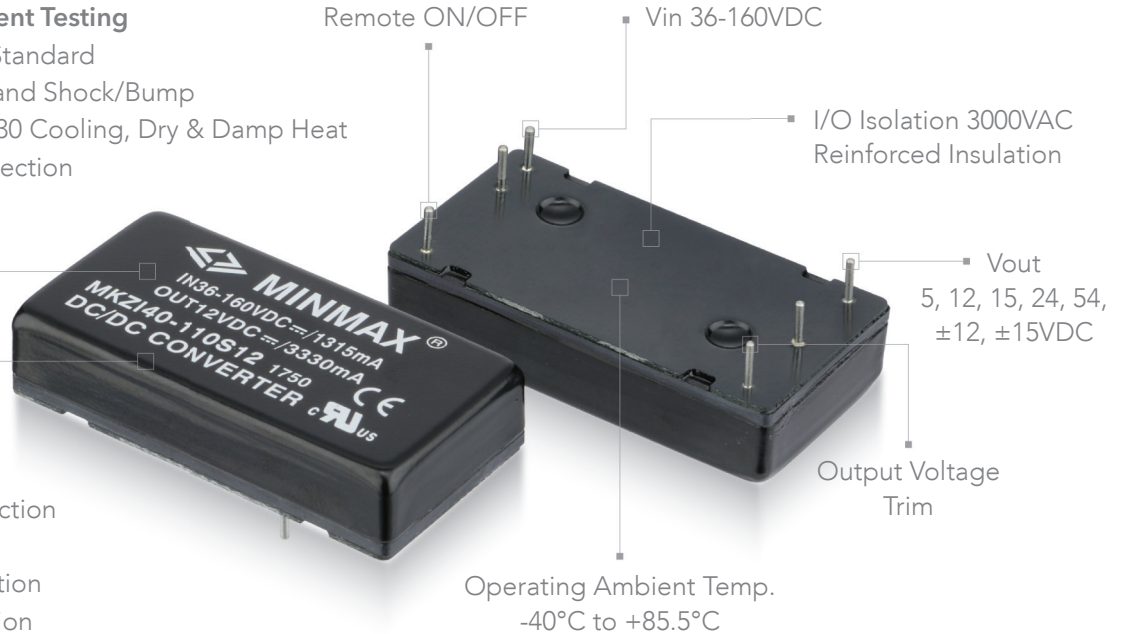

Features

- ◆ Industrial Standard 2" x 1" Package
- ◆ Ultra-wide Input Range 36-160VDC
- ◆ I/O Isolation 3000VAC with Reinforced Insulation
- ◆ Excellent Efficiency up to 90%
- ◆ Operating Ambient Temp. Range -40°C to +85.5°C
- ◆ No Min. Load Requirement
- ◆ Under-Voltage, Overload/Voltage and Short Circuit Protection
- ◆ Remote On/Off Control, Output Voltage Trim
- ◆ Vibration and Shock/Bump Test EN 61373 Approved
- ◆ Cooling, Dry & Damp Heat Test IEC/EN 60068-2-1, 2, 30 Approved
- ◆ Railway EMC Standard EN 50121-3-2 Approved
- ◆ Railway Certified EN 50155 (IEC 60571) Approved
- ◆ Fire Protection Test EN 45545-2 Approved
- ◆ UL/cUL/IEC/EN 62368-1 Safety Approval & CE Marking

Model Selection Guide

Model Number	Input Voltage (VDC)	Output Voltage (VDC)	Output Current (mA)max	Efficiency
MKZI40-110S05		5	8000	88%
MKZI40-110S12		12	3330	89%
MKZI40-110S15		15	2670	89%
MKZI40-110S24	110 (36 - 160)	24	1670	89%
MKZI40-110S54		54	741	90%
MKZI40-110D12		±12	±1670	89%
MKZI40-110D15		±15	±1330	89%

*There are different features & spec. by each series.
For detailed series datasheet, please refer to www.minmax.com.tw

► Railway Certified • DC-DC Converters

50W

MTQZ50 Series



Protection

- Under Voltage Protection
- Overload Protection
- Over Voltage Protection
- Over Temp. Protection
- Short Circuit Protection

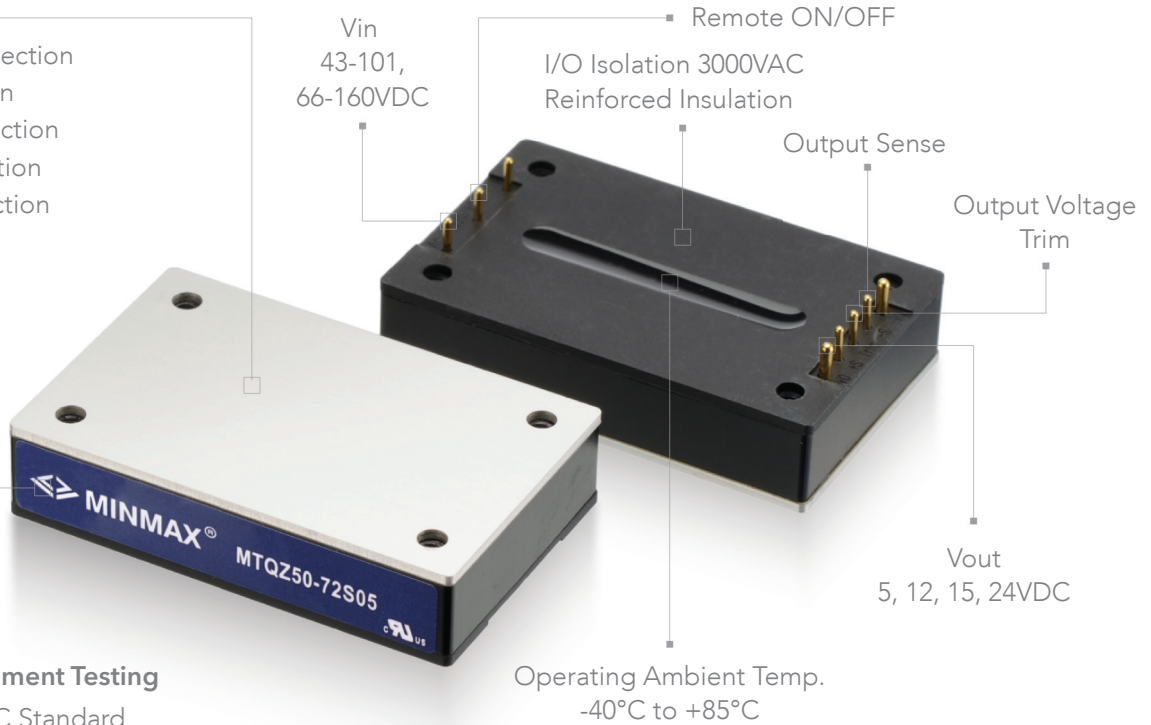

EMC and Environment Testing

- EN 50121-3-2 EMC Standard
- EN 61373 Vibration and Shock/Bump
- IEC/EN 60068-2-1,2,30 Cooling, Dry & Damp Heat
- EN 45545-2 Fire Protection

Features

- ◆ Industrial Standard Quarter Brick Package
- ◆ Wide Input Range 43-101VDC & 66-160VDC
- ◆ Excellent Efficiency up to 92%
- ◆ I/O Isolation 3000VAC with Reinforced Insulation
- ◆ Operating Ambient Temp. Range -40°C to +85°C
- ◆ No Min. Load Requirement
- ◆ Under-Voltage, Overload/Voltage/Temp. and Short Circuit Protection
- ◆ Remote On/Off Control, Output Voltage Trim, Output Sense
- ◆ Vibration and Shock/Bump Test EN 61373 Approved
- ◆ Cooling, Dry & Damp Heat Test IEC/EN 60068-2-1, 2, 30 Approved
- ◆ Railway EMC Standard EN 50121-3-2 Approved
- ◆ Railway Certified EN 50155 (IEC 60571) Approved
- ◆ Fire Protection Test EN 45545-2 Approved
- ◆ UL/cUL/IEC/EN 62368-1(60950-1) Safety Approval & CE Marking

Model Selection Guide

Model Number	Input Voltage (VDC)	Output Voltage (VDC)	Output Current (mA)max	Efficiency
MTQZ50-72S05	72 (43 - 101)	5	10000	90%
MTQZ50-72S12		12	4170	92%
MTQZ50-72S15		15	3330	92%
MTQZ50-72S24		24	2080	91%
MTQZ50-110S05	110 (66 - 160)	5	10000	90%
MTQZ50-110S12		12	4170	91%
MTQZ50-110S15		15	3330	92%
MTQZ50-110S24		24	2080	91%

*There are different features & spec. by each series.
For detailed series datasheet, please refer to www.minmax.com.tw

► Railway Certified • DC-DC Converters

75W

MTQZ75 Series



Protection

- Under Voltage Protection
- Overload Protection
- Over Voltage Protection
- Over Temp. Protection
- Short Circuit Protection

Vin
43-101,
66-160VDC

Remote ON/OFF

I/O Isolation 3000VAC
Reinforced Insulation

Output Sense

Output Voltage
Trim

Vout
5, 12, 15, 24VDC

Operating Ambient Temp.
-40°C to +80°C

EMC and Environment Testing

- EN 50121-3-2 EMC Standard
- EN 61373 Vibration and Shock/Bump
- IEC/EN 60068-2-1,2,30 Cooling, Dry & Damp Heat
- EN 45545-2 Fire Protection

Features

- ◆ Industrial Standard Quarter Brick Package
- ◆ Wide Input Range 43-101VDC & 66-160VDC
- ◆ Excellent Efficiency up to 92%
- ◆ I/O Isolation 3000VAC with Reinforced Insulation
- ◆ Operating Ambient Temp. Range -40°C to +80°C
- ◆ No Min. Load Requirement
- ◆ Under-Voltage, Overload/Voltage/Temp. and Short Circuit Protection
- ◆ Remote On/Off Control, Output Voltage Trim, Output Sense
- ◆ Vibration and Shock/Bump Test EN 61373 Approved
- ◆ Cooling, Dry & Damp Heat Test IEC/EN 60068-2-1, 2, 30 Approved
- ◆ Railway EMC Standard EN 50121-3-2 Approved
- ◆ Railway Certified EN 50155 (IEC 60571) Approved
- ◆ Fire Protection Test EN 45545-2 Approved
- ◆ UL/cUL/IEC/EN 62368-1(60950-1) Safety Approval & CE Marking

Model Selection Guide

Model Number	Input Voltage (VDC)	Output Voltage (VDC)	Output Current (mA)max	Efficiency
MTQZ75-72S05	72 (43 - 101)	5	15000	89%
MTQZ75-72S12		12	6250	92%
MTQZ75-72S15		15	5000	92%
MTQZ75-72S24		24	3125	91%
MTQZ75-110S05	110 (66 - 160)	5	15000	89%
MTQZ75-110S12		12	6250	91%
MTQZ75-110S15		15	5000	91%
MTQZ75-110S24		24	3125	90%

*There are different features & spec. by each series.
For detailed series datasheet, please refer to www.minmax.com.tw

► Railway Certified • DC-DC Converters

100W

MTQZI100 Series **NEW**



Protection

- Under Voltage Protection
- Overload Protection
- Over Voltage Protection
- Over Temp. Protection
- Short Circuit Protection



EMC and Environment Testing

- EN 50121-3-2 EMC Standard
- EN 61373 Vibration and Shock/Bump
- IEC/EN 60068-2-1,2,30 Cooling, Dry & Damp Heat
- EN 45545-2 Fire Protection

Operating Base Plate Temp. Range
-40°C to +105°C

Features

- ◆ Industrial Standard Quarter Brick Package
- ◆ Ultra-wide Input Range 40-160VDC
- ◆ Excellent Efficiency up to 91.5%
- ◆ I/O Isolation 3000VAC with Reinforced Insulation
- ◆ Operating Base Plate Temp. Range -40°C to +105°C
- ◆ No Min. Load Requirement
- ◆ Under-Voltage, Overload/Voltage/Temp. and Short Circuit Protection
- ◆ Remote On/Off Control, Output Voltage Trim, Output Sense
- ◆ Vibration and Shock/Bump Test EN 61373 Approved
- ◆ Cooling, Dry & Damp Heat Test IEC/EN 60068-2-1, 2, 30 Approved
- ◆ Railway EMC Standard EN 50121-3-2 Approved
- ◆ Railway Certified EN 50155 (IEC 60571) Approved
- ◆ Fire Protection Test EN 45545-2 Approved
- ◆ UL/cUL/IEC/EN 62368-1 Safety Approval & CE Marking

Model Selection Guide

Model Number	Input Voltage (VDC)	Output Voltage (VDC)	Output Current (A)max	Efficiency
MTQZI100-110S05		5	20	91.5%
MTQZI100-110S12		12	8.4	91%
MTQZI100-110S15	110 (40 - 160)	15	6.7	90.5%
MTQZI100-110S24		24	4.2	89%
MTQZI100-110S54		54	1.85	89%

*There are different features & spec. by each series.
For detailed series datasheet, please refer to www.minmax.com.tw

► Railway Certified • DC-DC Converters

150W

MTQZI150 Series **NEW**



Protection

- Under Voltage Protection
- Overload Protection
- Over Voltage Protection
- Over Temp. Protection
- Short Circuit Protection

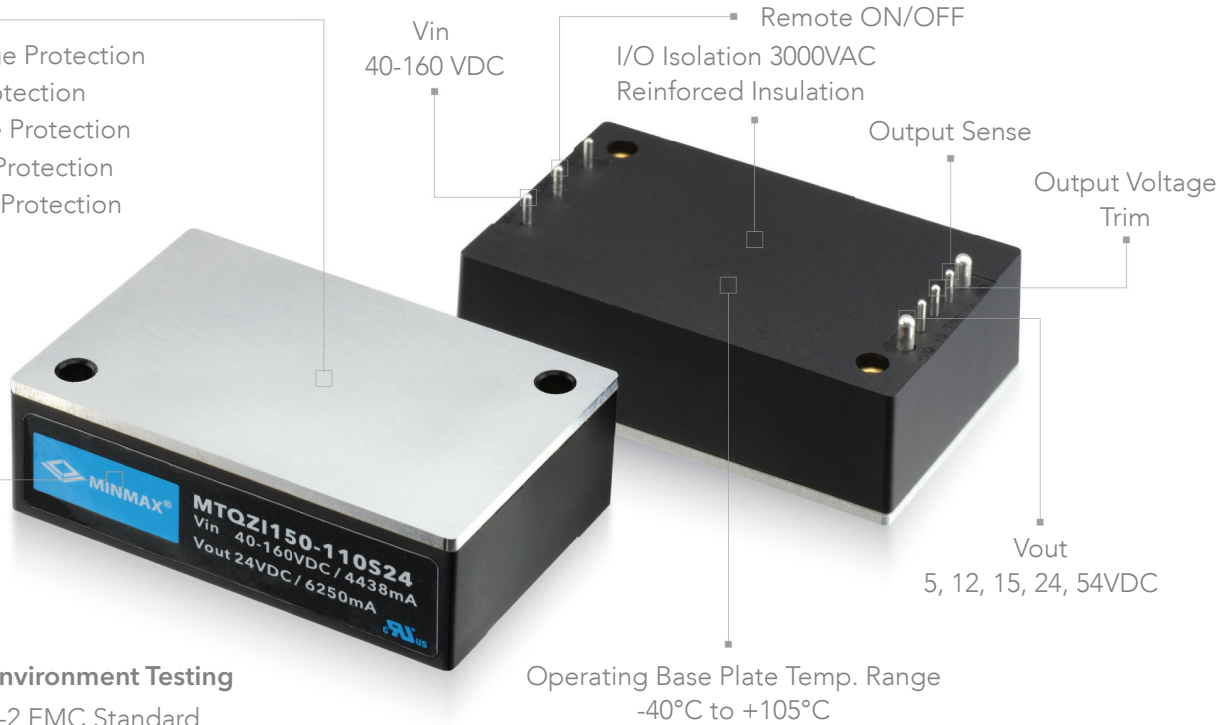

EMC and Environment Testing

- EN 50121-3-2 EMC Standard
- EN 61373 Vibration and Shock/Bump
- IEC/EN 60068-2-1,2,30 Cooling, Dry & Damp Heat
- EN 45545-2 Fire Protection

Features

- ◆ Industrial Standard Quarter Brick Package
- ◆ Ultra-wide Input Range 40-160VDC
- ◆ Excellent Efficiency up to 90%
- ◆ I/O Isolation 3000VAC with Reinforced Insulation
- ◆ Operating Base Plate Temp. Range -40°C to +105°C
- ◆ No Min. Load Requirement
- ◆ Under-Voltage, Overload/Voltage/Temp. and Short Circuit Protection
- ◆ Remote On/Off Control, Output Voltage Trim, Output Sense
- ◆ Vibration and Shock/Bump Test EN 61373 Approved
- ◆ Cooling, Dry & Damp Heat Test IEC/EN 60068-2-1, 2, 30 Approved
- ◆ Railway EMC Standard EN 50121-3-2 Approved
- ◆ Railway Certified EN 50155 (IEC 60571) Approved
- ◆ Fire Protection Test EN 45545-2 Approved
- ◆ UL/cUL/IEC/EN 62368-1 Safety Approval & CE Marking

Model Selection Guide

Model Number	Input Voltage (VDC)	Output Voltage (VDC)	Output Current (A)max	Efficiency
MTQZI150-110S05		5	27	90%
MTQZI150-110S12		12	12.5	90%
MTQZI150-110S15	110 (40 - 160)	15	10	89%
MTQZI150-110S24		24	6.25	88%
MTQZI150-110S54		54	2.78	88.5%

*There are different features & spec. by each series.
For detailed series datasheet, please refer to www.minmax.com.tw



GENERAL INDUSTRIAL POWER SOLUTIONS

Our general industrial DC-DC converters are used in every corner of modern equipment & systems about everywhere.

We offer different electrical specifications and create competitive advantage performance to meet your critical design.

DC-DC CONVERTERS

- 1-5W** | SIP Package **1-12W** | DIP Package **40-50W** | 2"×1" Package **0.5-1A** | Switching Regulators
- 1-6W** | SMD Package **10-30W** | 1"×1" Package **6-60W** | Chassis & DIN-Rail Mounting

AC-DC POWER SUPPLIES

- 3-60W** | Encapsulated Package



ULTRA-HIGH ISOLATION POWER SOLUTIONS

Ultra-high isolation family equipped with very high common mode transient immunity with 15KV/μs qualifies and I/O isolation 4000 to 5000VAC with reinforced insulation, rated for 1000Vrms working voltage.

DC-DC CONVERTERS

- 1-2W** | SIP Package **2-10W** | DIP Package **15-20W** | 2"×1" Package **6-60W** | Chassis & DIN-Rail Mounting



RAILWAY CERTIFIED POWER SOLUTIONS

Our railway certified DC-DC converters are designed for stringent requirements and harsh environment. The products family are I/O isolation 3000 VAC with reinforced insulation. Furthermore, all railway products comply with EN 50155 certified and fire protection EN 45545-2 approval.

DC-DC CONVERTERS

- 3W** | DIP Package **50-150W** | Quarter Brick
- 10-40W** | 2"×1" Package



MEDICAL SAFETY POWER SOLUTIONS

The medical grade DC-DC converters & AC-DC Power Supplies for demanding applications in both medical and healthcare instrumentations. All medical products are approved to latest medical safety standards: ANSI/AAMI ES 60601-1, IEC/EN 60601-1 3rd edition with 2xMOPP/2xMOOP.

DC-DC CONVERTERS

- 1W** | SIP Package **1-2W** | SMD Package **2-10W** | DIP Package **15-20W** | 2"×1" Package

AC-DC POWER SUPPLIES

- 24-60W** | Encapsulated Package

* If there is any mistake in the document, please follow the official datasheet. www.minmax.com.tw

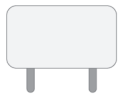

Note

If there is any mistake in the document, please follow the official datasheet.(www.minmax.com.tw)

for more info., please go to
www.minmax.com.tw



MINMAX TECHNOLOGY CO., LTD.

No.18, Sin Sin Rd., An-Ping Industrial Dist., Tainan 702 Taiwan



+886-6-2923150



+886-6-2923149



sales@minmax.com.tw